

# Deployable CMOSS MOSA System

## 800 Series Systems

This HPEC ATR 3U system for SOSA aligned payloads is intended for use in demanding RADAR, SIG-INT, EW and EA applications. The rugged design offers an ample I/O complement including multiple receiver and transmitter channels plus 1PPS and 10MHz Ref with a 10Gigabit Ethernet Fiber data interconnect making it an ideal C4ISR Modular Open Sensor System (CMOSS) for harsh environments. The system leverages LCR's 800 Series AoC3U-821 chassis for VITA 48.2 conduction cooled modules supporting 8 payload and 2 VITA 62 PSU slots plus a removable solid state drive bay. LCR can integrate a high-performance Intel Xeon processor and Nvidia GPGPU, providing nearly 10TFLOPs of computational power to meet the high bandwidth signal I/O requirements in today's mission critical deployments. Each FPGA sub-system has backplane Ethernet connections to a 40 GigE switch providing copper or optical I/O through customizable 38999 connectors to the front panel. The FPGA sub-system has a full meshed 40Gigabit capable network between each VPX card. The system maintains SOSA alignment to the connector level for future tech refresh deployments. It is designed to accommodate best-in-class 3U CMOSS and SOSA aligned payloads to meet mission needs with minimal time to theater.

**Contact LCR to discuss your specific configurations requirements.**

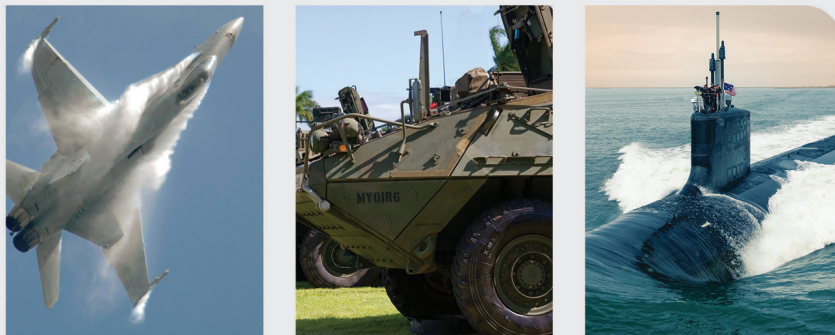

The system is intended for use in high power, high speed C4ISR (Command, Control, Communications, Computers, Intelligence, Surveillance and Reconnaissance) systems operating in mission critical defense applications.



### Payload Options

- Intel Xeon D processor with 576GFLOPs performance
- NVIDIA Pascal GP104 with 2560 CUDA cores and 8.7TFLOPs performance
- Scalable Xilinx FPGA subsystem
- Scalable tuner subsystem with VITA 49 IF packet compliance
- 40Gigabit layer 2/3 Ethernet Switch for fiber or copper I/O
- Removable SSD bay

### Standard Features

- Accommodate best-in-class 3U CMOSS and SOSA aligned payloads
- SOSA alignment to the connector level
- Custom I/O panel with MIL-STD 38999 options for high-speed copper, optical or RF signals
- Cooling for up to 575W of total power
- Conduction cooled VITA 48.2 chassis with air assist
- Designed for SWaP sensitive applications
- Based on LCR's proven 800 Series chassis design
- 8 payload and 2 VITA 62 PSU slots

**LCR Embedded Systems**

9 South Forrest Ave.  
Jeffersonville, PA 19403

CMOSS MOSA System Rev 2-2022

## BACKPLANE PROFILE

The system backplane supports both VITA67.c and VITA67.d apertures with dataplane and control plane connections to a 40GigE switch and has been optimized to distribute heat load to sensitive up/down converters.

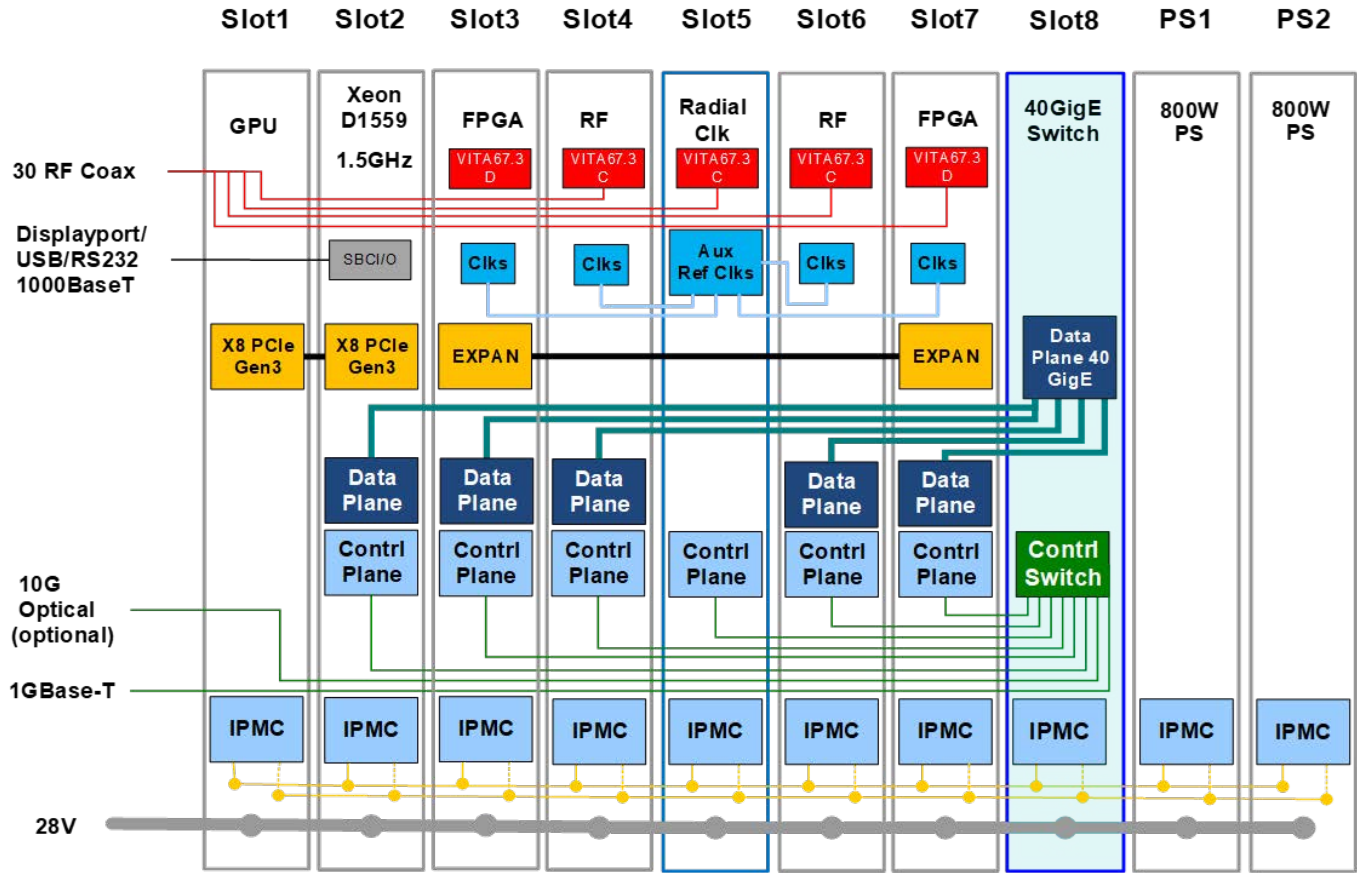

## SLOT PROFILES

This 800 Series CMOSS SOSA System backplane support these slot profiles in alignment with the SOSA technical standard.

- Slots 1, 2, 4 and 6 - CPU, GPU and Tuners
  - SLT3-PAY-1F1U1S1S1U1U2FIH-14.6.11
- Slot 5 - Radial Timing
  - TIM-2S1U22S1U2U1H-14.9.2-n
- Slots 3 and 7 - FPGA
  - SLT3-PAY-1F1U1S1S1U1U4FIJ-14.6.13
- Slot 8 Ethernet Switch
  - SLT3-SWH-6F1U7U-14.14.14

## BACKPLANE DRAWING

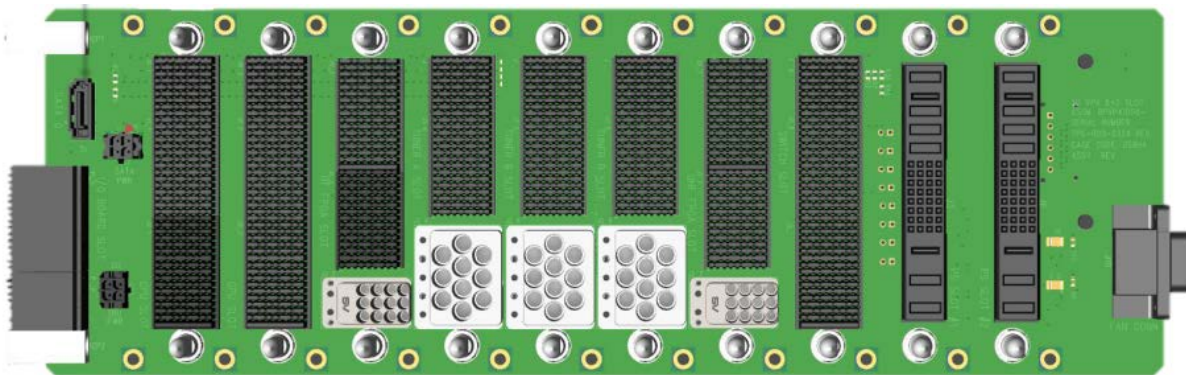

## PAYLOAD DESCRIPTION

### Processing Boards

Intel 1.5GHz 12 Core Xeon D processor with 576GFLOPs performance  
 Integrated 80GB SSD, 16 GB of DDR  
 10/40GBaseKR to the switch and 8x Gen3 PCIe to GPGPU  
 SLT3-PAY-1F1U1S1S1U1U2FIH-14.6.11

NVIDIA Pascal GP104 with 2560 CUDA cores and 8.7TFLOPs performance  
 16GB of GDDR5 memory  
 SLT3-PAY-1F1U1S1S1U1U2FIH-14.6.11

### Tuner Boards

Each with 6GHz 2 down / 2 up converters and 100MHz VITA 49 IF packet output via 10/40GBaseBX ports to the Ethernet to switch  
 SLT3-PAY-1F1U1S1S1U1U2FIH-14.6.11

### FPGA Boards

Xilinx UltraScale+ XCVU9P with 1 GB of DDR, 8 channels 4-5GSPS ADC and 2 channels of 6-10GSPS DAC Auxiliary quad core Arm processor with 32GB SSD  
 SLT3-PAY-1F1U1S1S1U1U4FIJ-14.6.13

### Ethernet Switch

40Gigabit layer 2/3 Ethernet Switch with two SFP connectivity for fiber or copper to I/O panel  
 SLT3-SWH-6F1U7U-14.14.14

### Radial Timing

REF/Aux sync clock to FPGA and Tuner payloads with GPS and external 1PPS and 10MHz ref input.  
 SLT3x-TIM-2S1U22S1U2U1H-14.9.2-n

## Chassis Dimensions

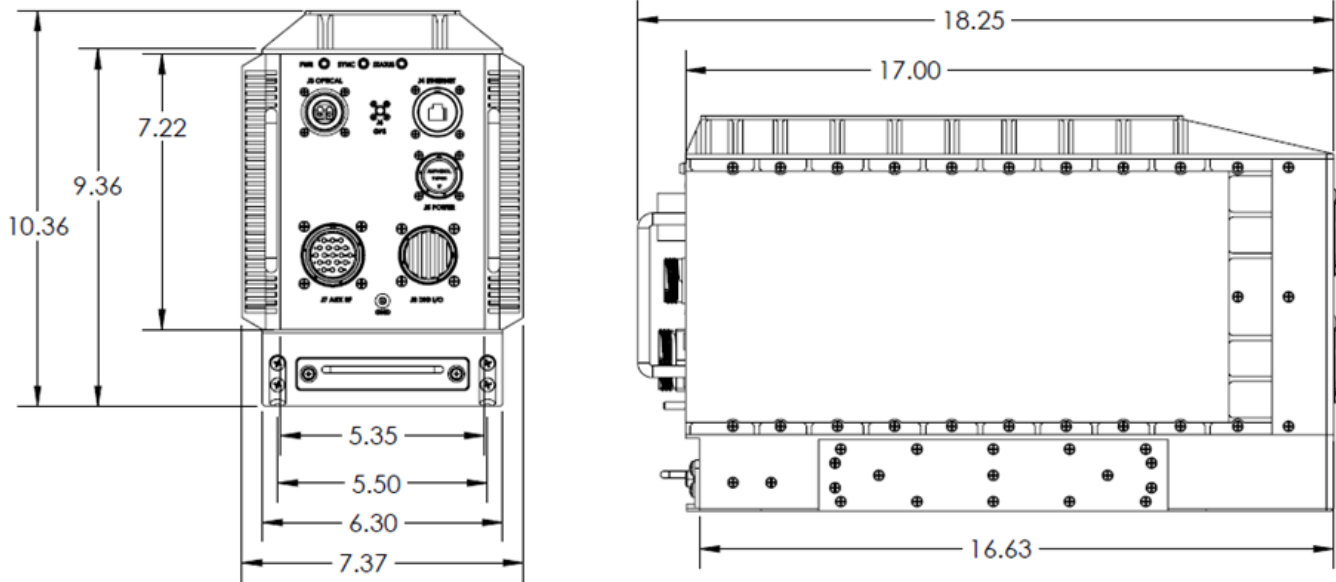

Front panel I/O may be customized to accommodate any signal complement. LCR's engineering team will work to address specific connector types and locations for high speed copper, fiber or RF as required for most applications.

SPECIFICATIONS	
<b>Physical</b>	<b>Backplane options</b>
Dimensions: 10.35" (H), 7.5 (W) x 18.25" (D) incl. handles and connectors 191mm x 263mm x 464mm including connectors and mounting plate Machined aluminum alloy 6061-T6, bolt together construction Weight: Approximately 38lbs, no payload boards	Custom 8 +2 payload to power supply slot backplane VPX and SOSA aligned slot profiles 10, 40 and 100GBase KR4 capable VITA 66 and 67 optical and RF apertures
<b>Thermal</b>	<b>I/O Capabilities</b>
Operating: -40°C to 55°C 4 x high cfm fans Max altitude 15Kft at 575W and 30Kft for sub 575W payloads	Custom I/O panel supporting high speed connectivity High density MIL-STD 38999 circular connectors High speed 10GbE 38999 Hercules connectors Rugged SMA connectors for RF and optical I/O
<b>Environmental</b>	<b>Payload Compatibility</b>
Shock: 30 Gs @ 11ms half sine Vibration: 20 to 2000Hz at 5Gs Designed to meet MIL-STD-810, MIL-STD-461, and MIL-S-901D	3U VPX multi-core single board computers, high speed GPGPU and FPGA modules, video processing and Ethernet switching
<b>Power Supply</b>	<b>Applications</b>
2 VITA 62 pluggable power supply supporting 12 and 5V modules MIL-STD-704E, MIL-STD-1275 Input voltage: 18 to 36 VDC Output: up to 1400W total	Mission computing, systems command and control digital recording systems, digital signal processing, high speed data acquisition, video displays in defense assets operating in demanding environments

ORDER NUMBER	DESCRIPTION
Consult LCR Sales	HPEC ATR 3U OpenVPX system including Intel Xeon D processor, NVIDIA Pascal GPGPU, a scalable Xilinx UltraScale FPGA subsystem, scalable tuner subsystem, 40Gigabit layer 2/3 Ethernet Switch for fiber or copper I/O, dual VITA 62 PSU's and removable drive bay. <b>Contact LCR to discuss your specific configurations requirements.</b>

**LCR** provides a full line of VPX products and services - everything you need from development to deployment including; COTS rugged application ready chassis solutions as well as custom designs, custom 3U VPX backplanes supporting the latest slot profiles plus development tools including load boards and test fixtures.