



AoC3U-210

Dual Slot 3U VPX Packaging

Supporting RF EW and SIGINT operations deployed in harsh environments

The AoC3U-210 is a rugged packaging solution designed for 3U VPX and SOSA aligned payload cards supporting high speed connectivity with GbE, 10GbE, RF and optical interfaces. The compact and lightweight design addresses a wide range of EW / ISR and radar uses in ground and airborne assets where size constraints and functional performance in demanding environments are key. The chassis is ideally suited for software defined radio / RF tuner content as well as new RFSoc board designs for 3U VPX. It is intended for sensor systems in C5ISR applications where programs mandate SOSA aligned plug in payload cards in accordance with the DoD hardware and software convergence initiative. Secure internal interconnections ensure the signal integrity and signal speed requirements of these sensitive and critical applications. Custom and standard 3 slot backplanes include 2 payload slots and 1 power supply slot. The AoC3U-210 is a VITA 48.2 conduction cooled chassis with air assist and incorporates a dual high cfm fan bank for optimal heat dissipation. The customizable I/O panel enables variations of connectors for application specific signal requirements.



The AoC3U-210 is a robust packaging solution for use in sensor applications where high speed RF and optical processing payload modules are deployed in EW / ISR operations and a range of radar applications. It is also designed to enable airborne, dismounted, mounted usage for many critical defense applications.

Features

- Thermal load cooling up to 200W
- Custom backplane supporting SOSA aligned and VPX slot profiles and VITA 66 and 67 apertures
- Custom I/O panel with options for high speed RF, copper and optical signals
- Gasketing for protection against EMI and environmental ingress
- Front panel space for I/O complements and connectors types including 38999, SMA ports and others
- VITA 62 pluggable power supply
- Secure internal connections ensure the signal integrity and signal speed requirements
- Designed for VITA 48.2 conduction cooled boards.
- AoC design provides high cfm air flow
- Single uni-body chassis
- Designed to meet 55C ambient temperature requirements

Benefits

- Compact light weight design for SWaP sensitive applications
- Enhanced cooling for high TDP operation
- Rugged construction for optimal performance in demanding environments

SPECIFICATIONS

Physical

Dimensions: 4.31" (H) x 6.5" (W) x 14.125" (D)
 109mm x 165mm x 343mm including connectors and mounting plate
 Machined aluminum alloy 6061-T6, bolt together construction
 Weight: Approximately 13lbs including payload

Backplane options

Custom dual slot backplanes for 3U VPX, SOSA aligned module profiles including VITA 67.1 RF and VITA 66.4 optical apertures

Thermal

Operating: -40°C to 55°C 2 x high cfm fans
 Thermal load: Up to 200W

I/O Capabilities

Custom I/O panel supporting high speed connectivity
 High density MIL-STD 38999 circular connectors
 High speed 10GbE 38999 connectors, rugged SMA
 and Mighty Mouse connectors for RF and optical I/O

Environmental

Shock: 30Gs @ 11ms half sine
 Vibration: 20 to 2000Hz at 5Gs
 Designed to meet MIL-STD-810 test methods 516.8 and 514.8
 Designed to meet MIL-STD-461 CE102, CS101, CS114, CS115, CS116

Payload Compatibility

3U VPX and SOSA aligned payload boards supporting high speed RF, optical, GbE and 10GbE I/O requirements in defense programs that mandate SOSA aligned plug in cards

Power Supply

1 VITA 62 pluggable power supply supporting 12 and 5V modules
 MIL-STD-704E, MIL-STD-1275
 Input voltage: 18 to 36 VDC
 Output: up to 400W total

Applications

The AoC3U-210 is an advanced packaging solution intended for demanding environments. It enables deployment of counter ISR systems, multi-mission EW, navigational systems, air and ground surveillance radar, fire control radar, on the move radar, multi-mission radar systems at the tactical edge.

Chassis Dimensions

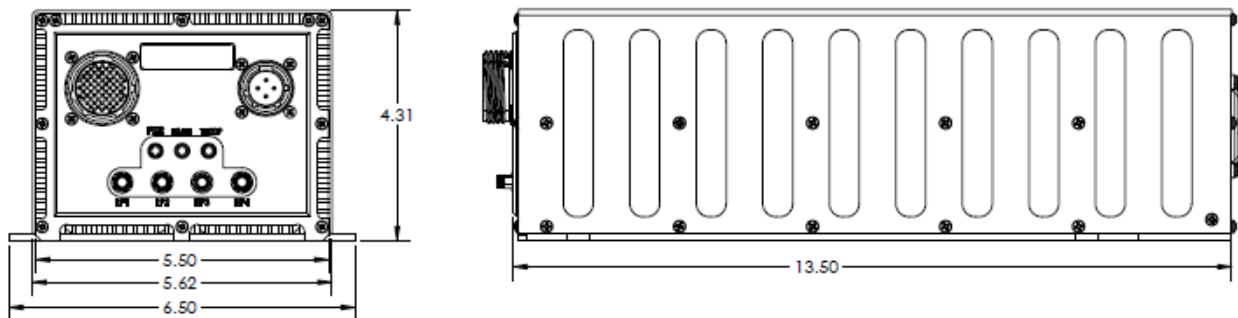

Sample I/O Panel Shown

LCR provides a full line of VPX products and services - everything you need from development to deployment including; COTS rugged application ready chassis solutions as well as custom designs, custom 3U VPX backplanes supporting the latest slot profiles plus development tools including load boards and test fixtures.

ORDER NUMBER

DESCRIPTION

Consult LCR Sales	AoC3U-210 conduction cooled chassis with air assist for 3UVPX module payloads. Part number and description based on final order configuration
Consult LCR Sales	CC3U-210 passive conduction cooled chassis for 3UVPX module payloads. Part number and description based on final order configuration

LCR Embedded Systems

9 South Forrest Ave.
 Jeffersonville, PA 19403